



SCHREIBTISCH
„BIRMINGHAM“ - RECHTSSEITIG

Artikel-Nr.: 1004

- AUFBAUANLEITUNG -



Installationsvideos und Aufbauanleitungen

zu unseren Produkten finden Sie unter

www.jet-line-e-trade.de

Nutzername: jet-line • Passwort: user2011

Weitere Produkte für Ihr Büro













finden Sie unter

<https://office-shopping.eu>

Produkt-Code:
Produkt-Maße:

1004 (rechts)
Höhe: ca. 760 mm, Breite: ca. 200 mm, Tiefe: ca. 100 mm

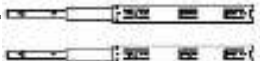
Teile-Liste:

A	Schraubdübel		44x
B	Exzenter-Verbinder		44x
C	Schraube		80x
D	Schraube		20x
E	Schraube		35x
F	Schraube		4x
G	Schraube		2x
H	Füße		10x
I	Scharnier		4x
J	Schloss		1x
K	Schubladen-Schienen		4x
L	Abstands-Halter		2x
M	Griff mit Schrauben		6x

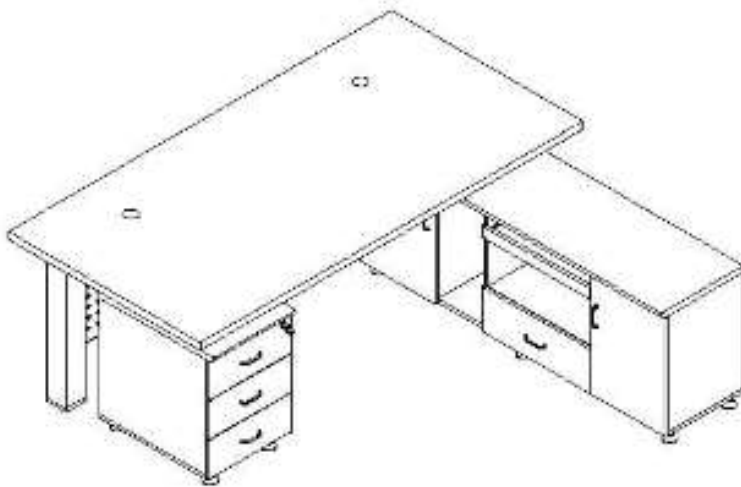

SCHRITT 1

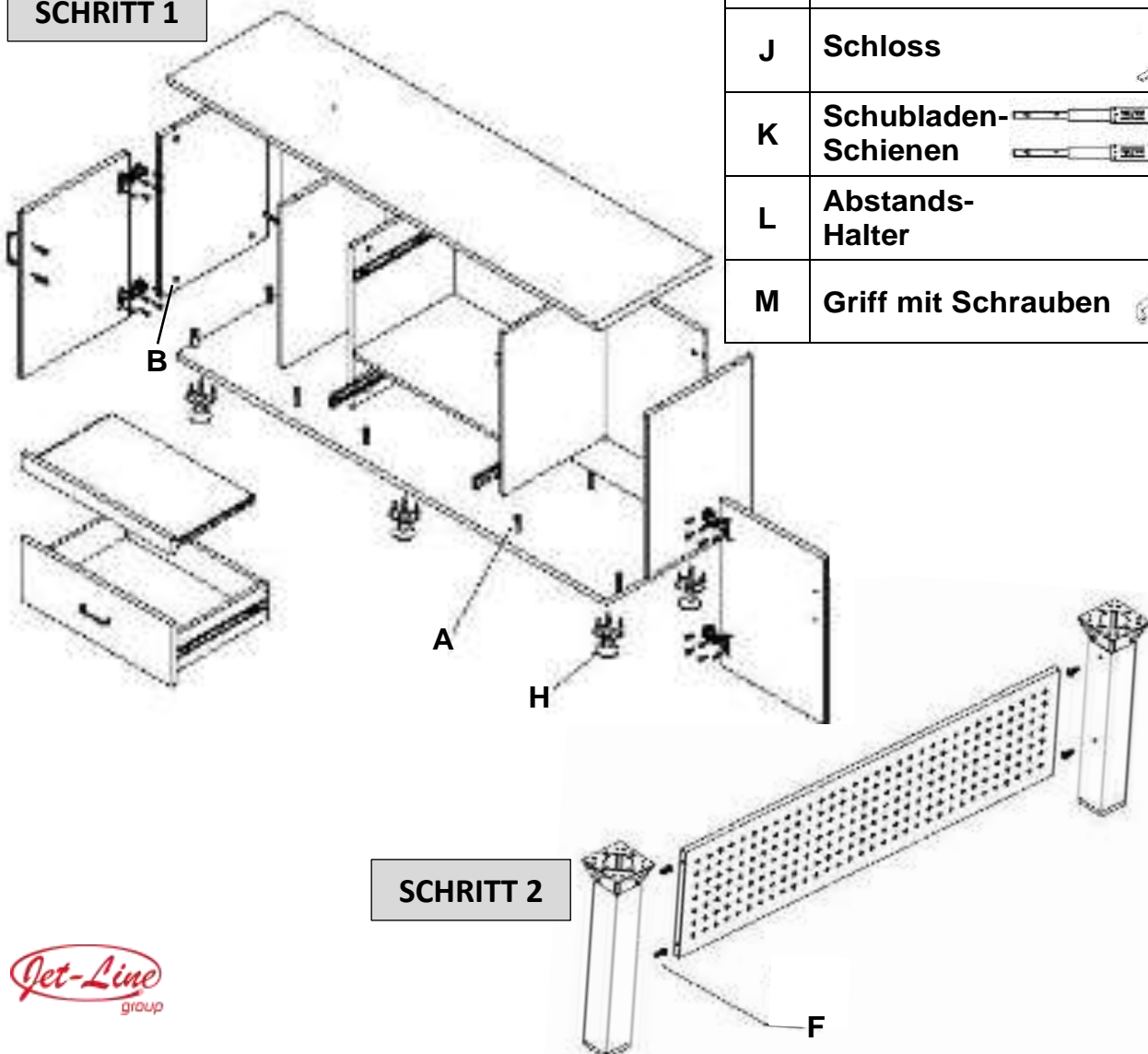

SCHRITT 2

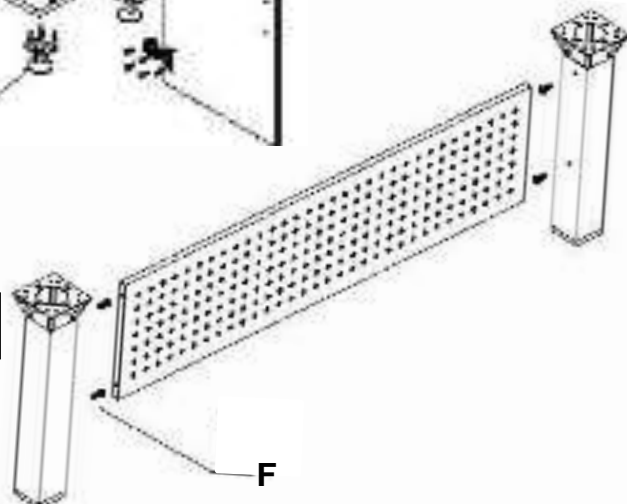

SCHRITT 3

Scharnier

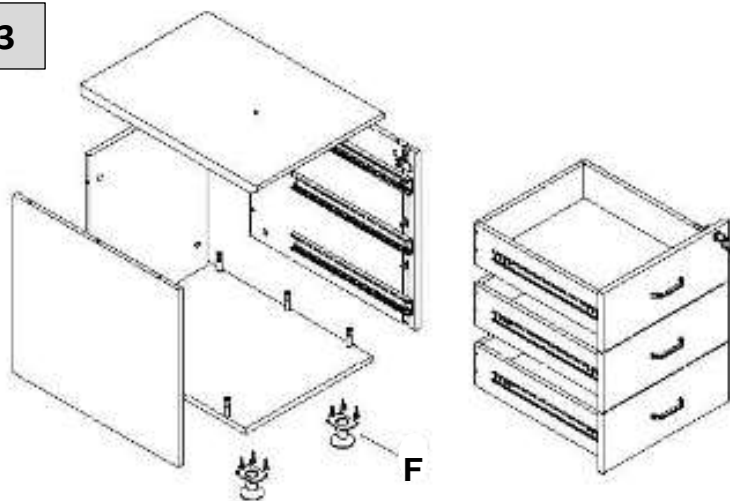

SCHRITT 4

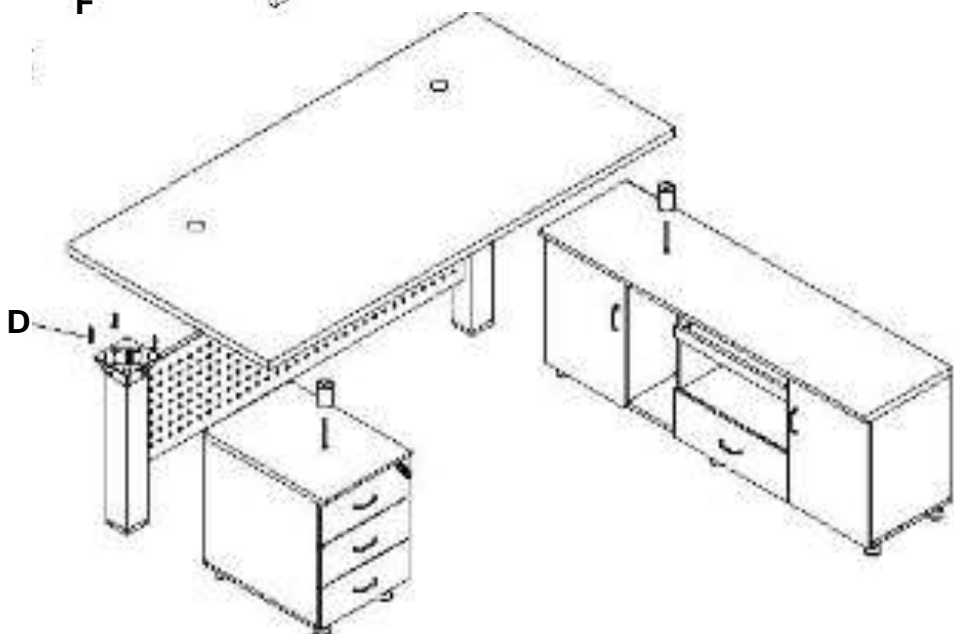

SCHRITT 5

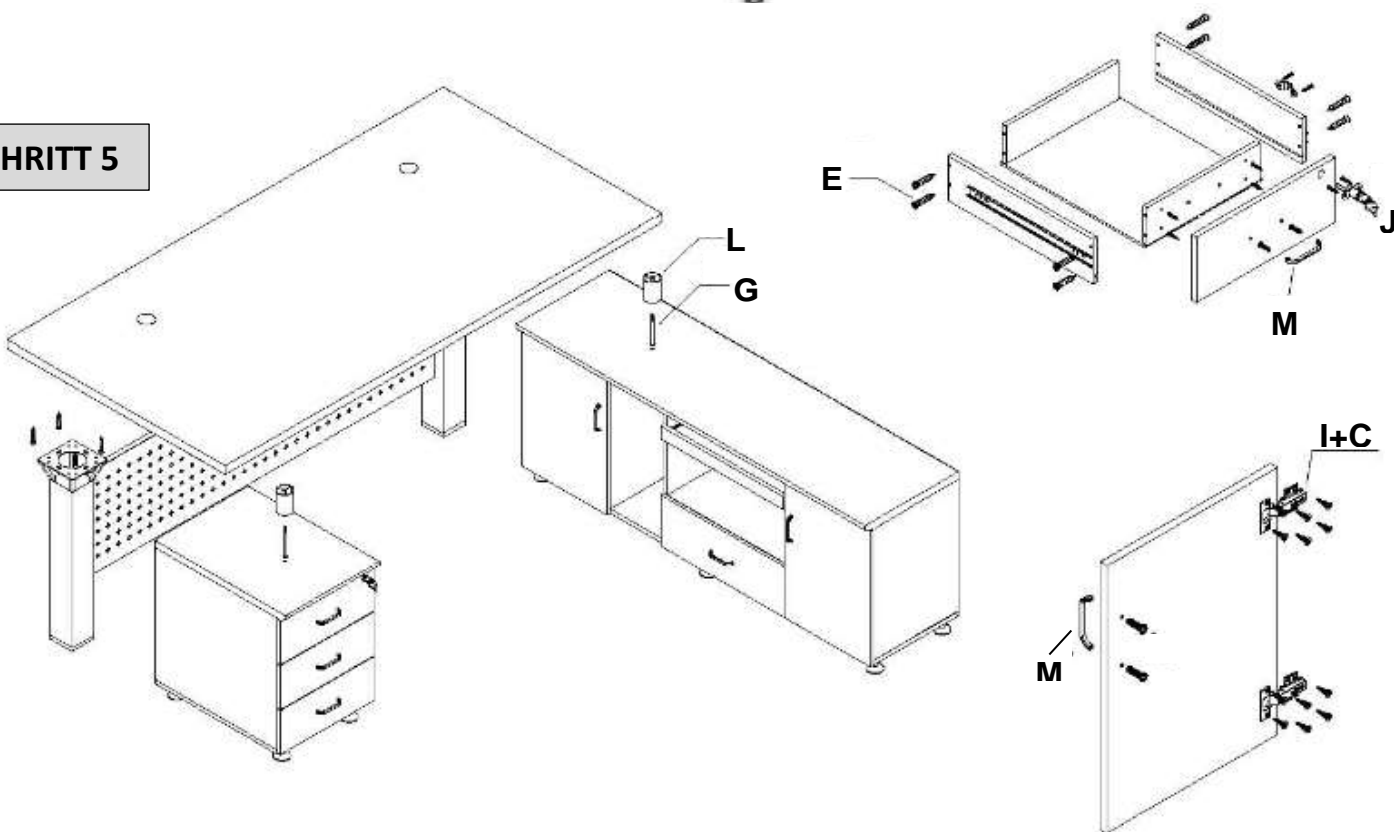

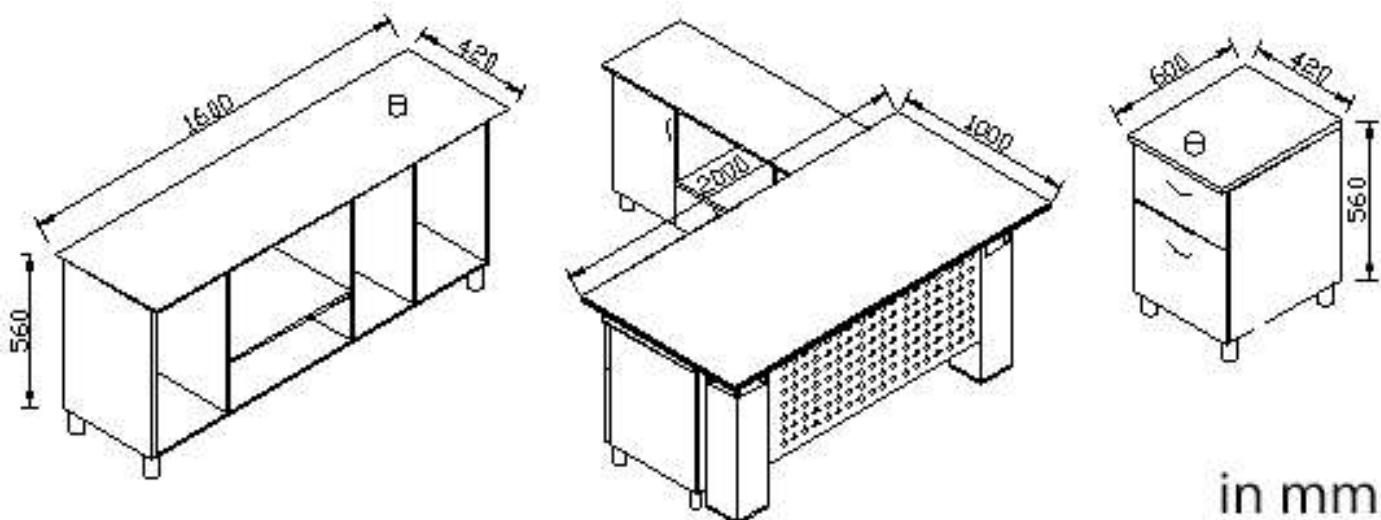

Installationsvideos und Aufbauanleitungen

zu unseren Produkten finden Sie unter

www.jet-line-e-trade.de

Nutzername: jet-line • Passwort: user2011

Weitere Produkte für Ihr Büro

finden Sie unter

<https://office-shopping.eu>



KBW Trading GmbH
 Gewerbering 2
 88518 Herbertingen
 Deutschland
 Tel: 07586-921160
 Fax: 07586-9211616
 E-Mail: info@jet-line.de
www.office-shopping.eu

