



**SCHREIBTISCH
„HERNE“ - LINKSSEITIG**

Artikel-Nr.: 12025

- AUFBAUANLEITUNG -



Installationsvideos und Aufbauanleitungen

zu unseren Produkten finden Sie unter

www.jet-line-e-trade.de

Nutzername: jet-line • Passwort: user2011





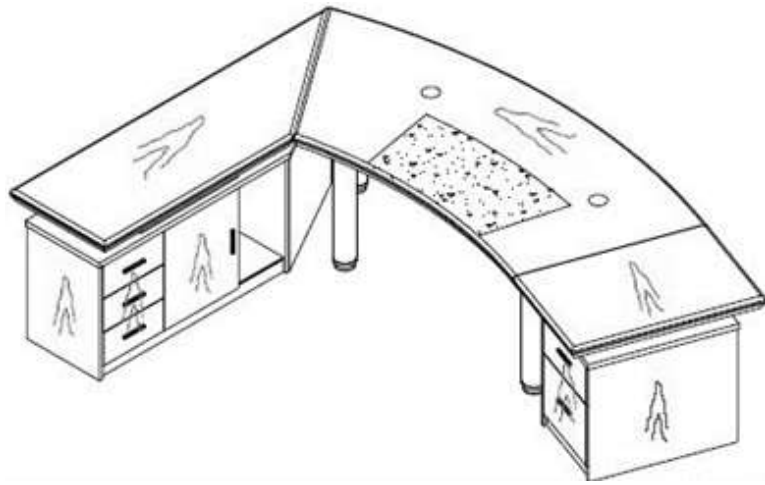

Weitere Produkte für Ihr Büro

finden Sie unter

<https://office-shopping.eu>



Teile-Liste:

A	Schraubdübel 15x35		38x
B	Exzenter- Verbinder 15x35		38x
C	Schraube 5x20		32x
D	Abstands- Halter		4x
E	Schraube 5x40		4x
F	Schraube M5x40		2x
G	Flach- Verbinder		4x

SCHRITT 1

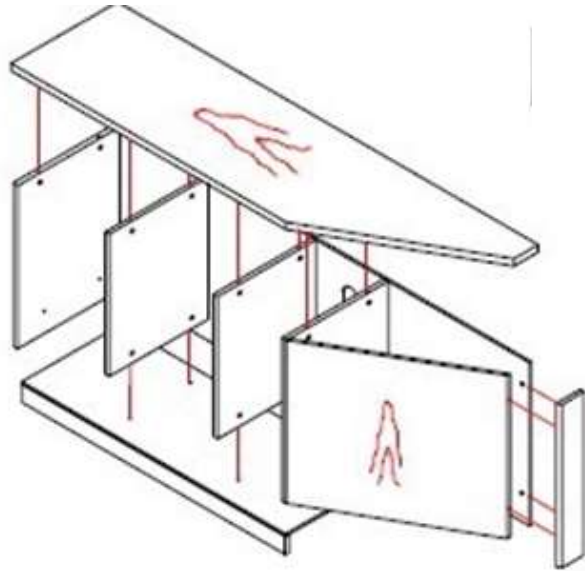
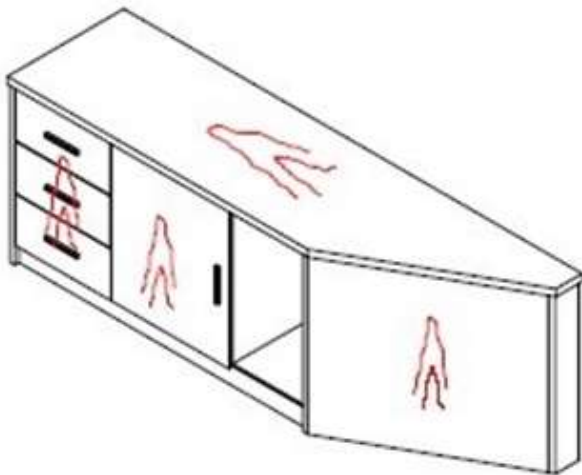

SCHRITT 2

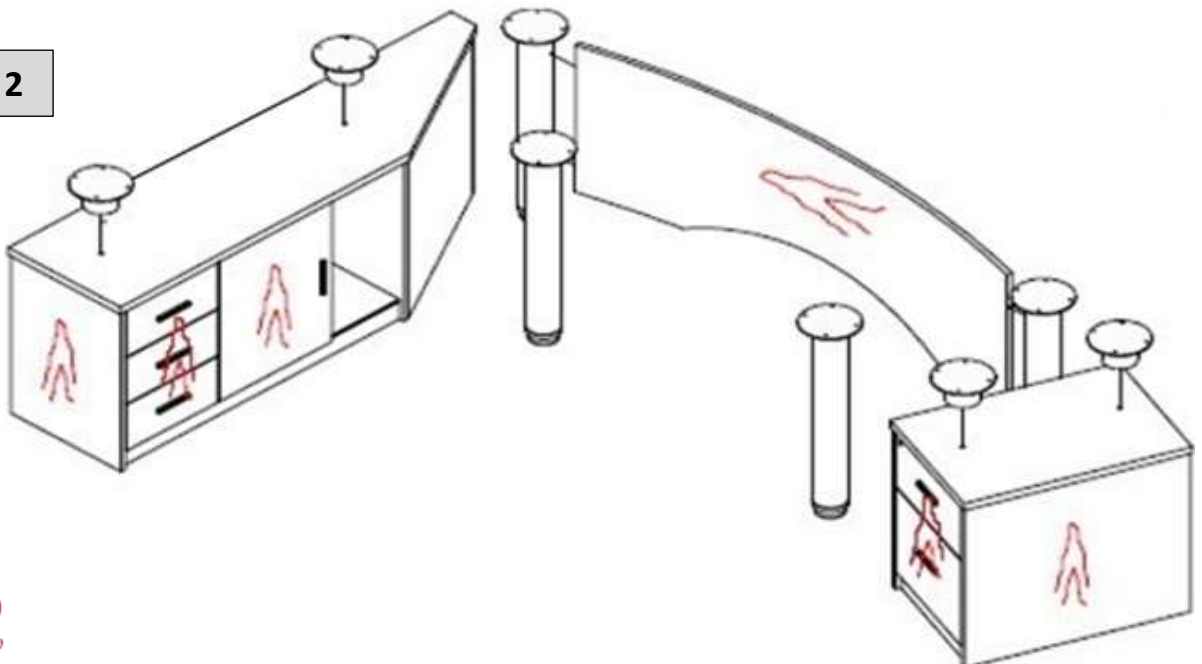

SCHRITT 3

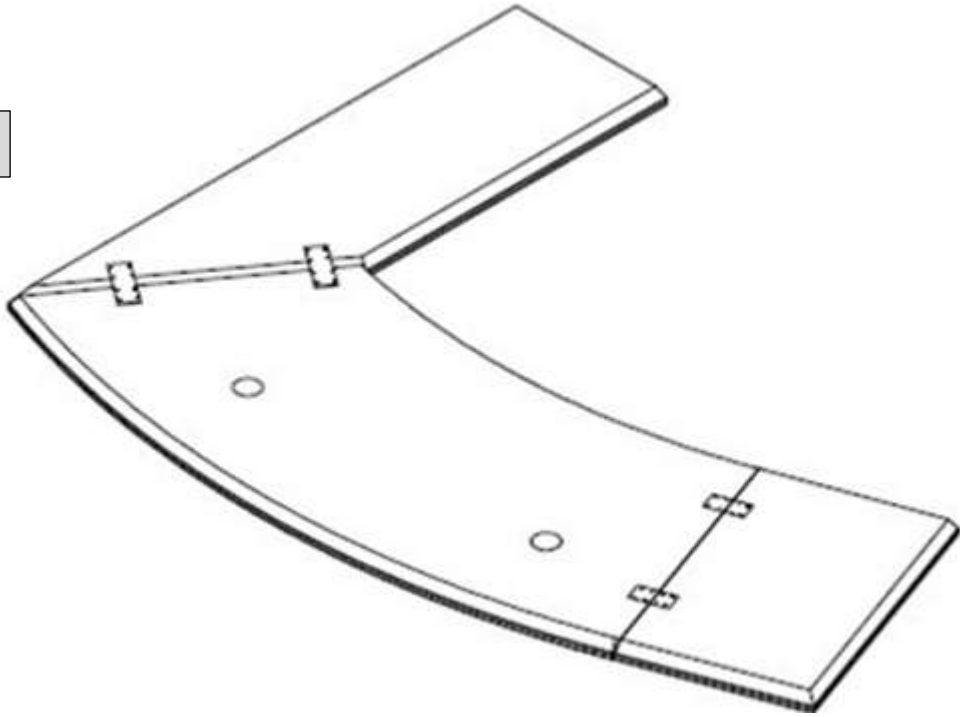

SCHRITT 4

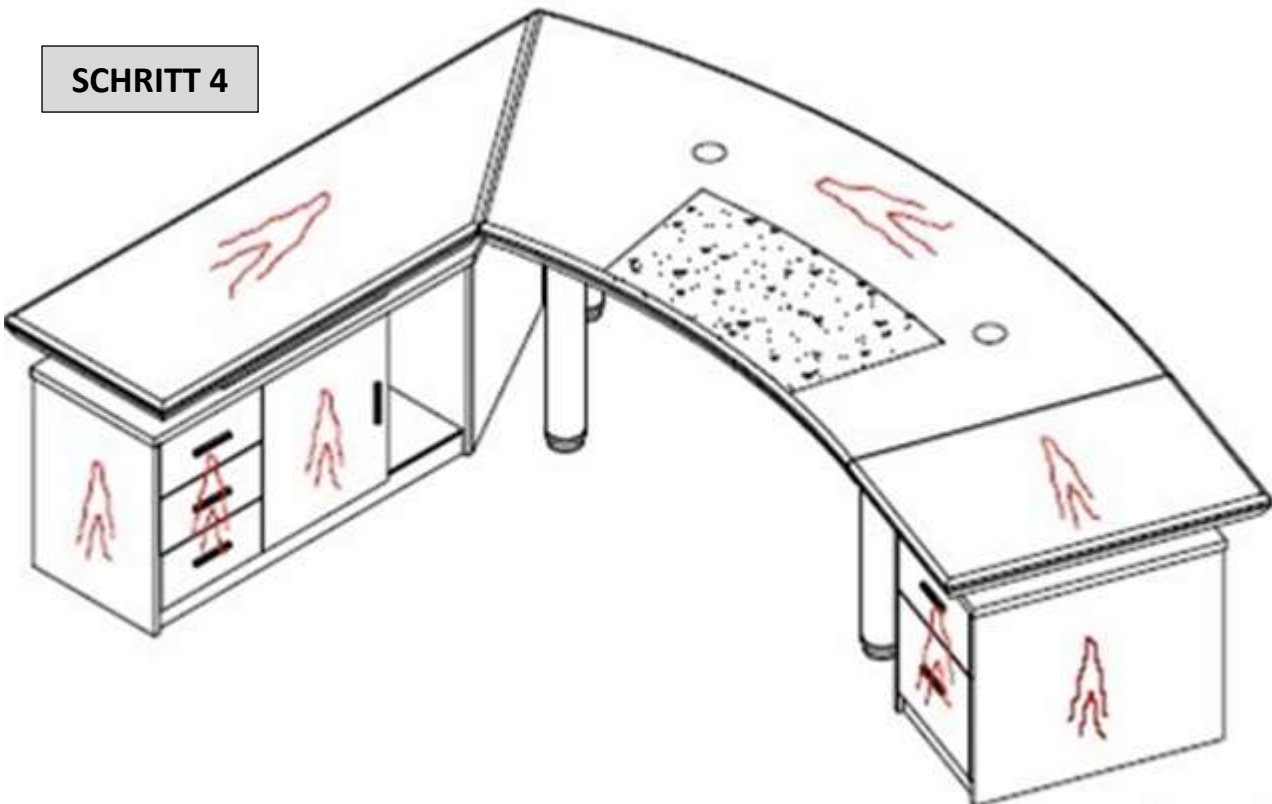

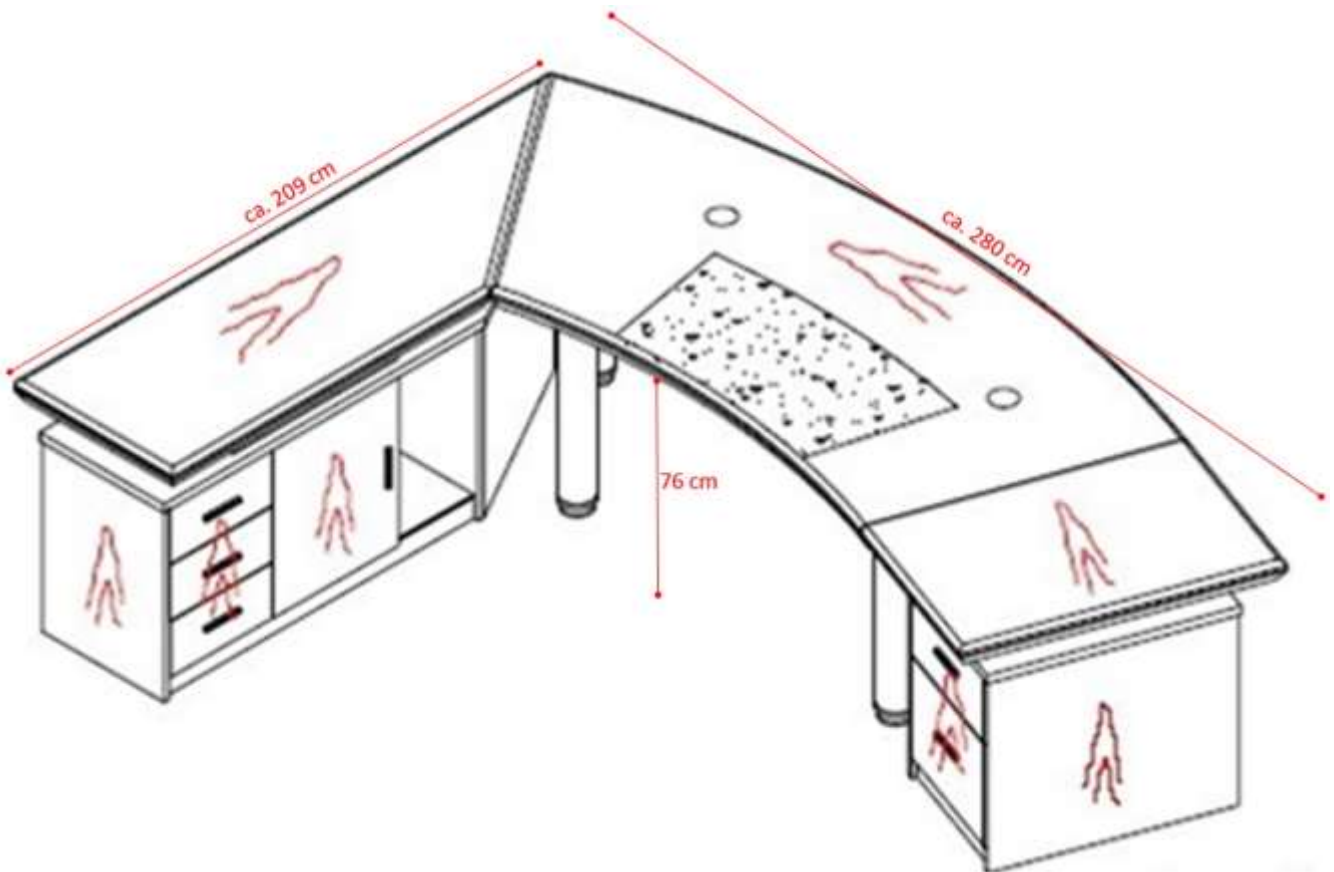

Installationsvideos und Aufbauanleitungen

zu unseren Produkten finden Sie unter

www.jet-line-e-trade.de

Nutzername: jet-line • Passwort: user2011

Weitere Produkte für Ihr Büro

finden Sie unter

<https://office-shopping.eu>



KBW Trading GmbH
Gewerbering 2
88518 Herbertingen
Deutschland
Tel: 07586-921160
Fax: 07586-9211616
E-Mail: info@jet-line.de
www.office-shopping.eu

