



## **GARTENPAVILLON „SUEZ“**

Artikel-Nr.: 23015

300 x 300 x 264 cm

- AUFBAUANLEITUNG -

























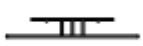

***Installationsvideos und Aufbauanleitungen***

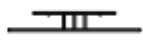











*zu unseren Produkten finden Sie  
in unserem Shop beim jeweiligen Produkt*



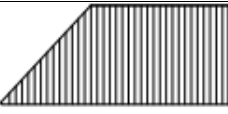
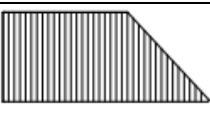

***Weitere Produkte für Haus und Garten***

*finden Sie unter  
[www.jet-line.de](http://www.jet-line.de)*

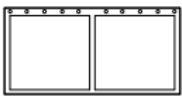
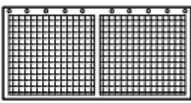
# Teile-Liste

Nr.	Abb.	Bezeichnung	Stz.
A			4
B			4
B1			4
C			4
D			4
E			4
E1			4
F			4
F1			4
G			4
G1			4
H			1
I			1
J			4
K			4

Nr.	Abb.	Bezeichnung	Stz.
K1			4
L			4
M			4
N			4
O			4
P			4
Q			4
R			8
S			4
S1			4
T			3
T1			2
V			80
W			4
X			4

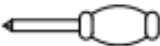
Nr.	Abb.	Bezeichnung	Stz.
AA		Schraube M6*20	66
BB		Schraube M6*15	96
CC		Schraube M5*15	24
DD		Schraube M5*15	4
EE	 4mm	Inbusschlüssel 4 mm	2
FF		Schraubenzieher	1

# Aufbauanleitung

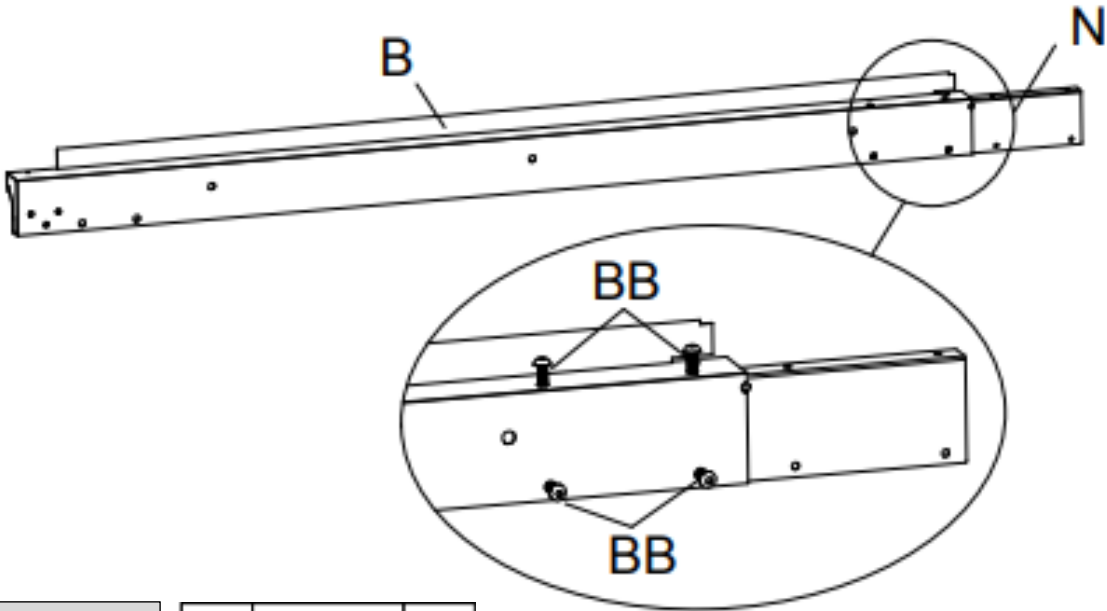

## SCHRITT 1

BB		M6*15	16
----	---	-------	----



X4

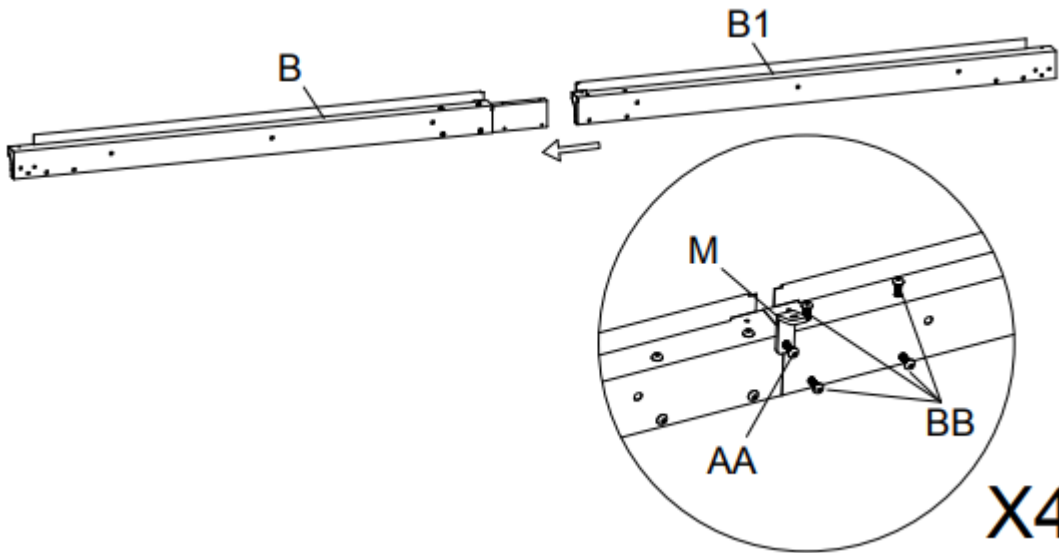

## SCHRITT 2

AA		M6*20	4
BB		M6*15	16
M			4



X4

**SCHRITT 3**

CC	 M5*15	8
DD	 M5*15	4
O		4

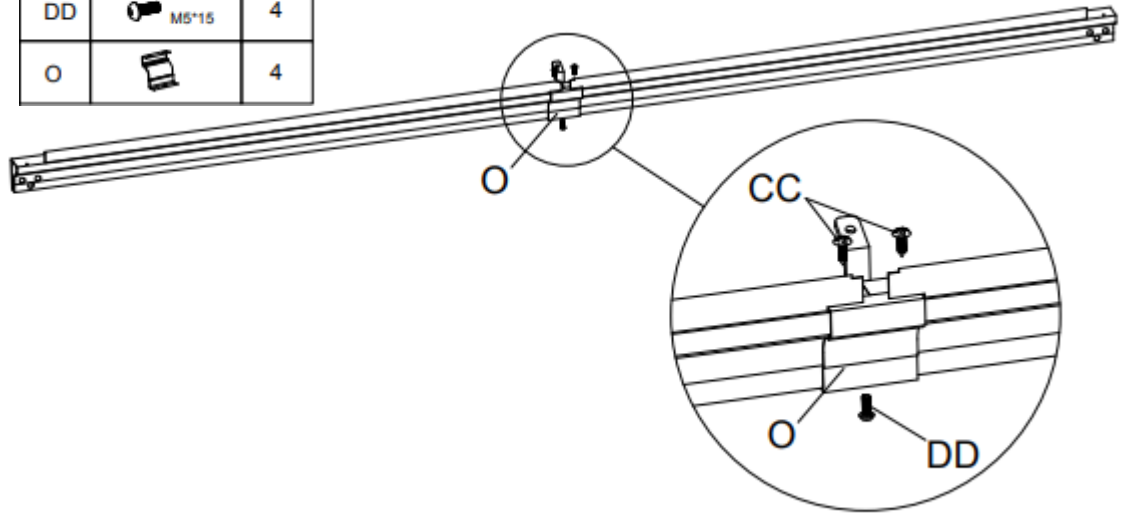

**X4**

**SCHRITT 4**

V		80
---	---	----

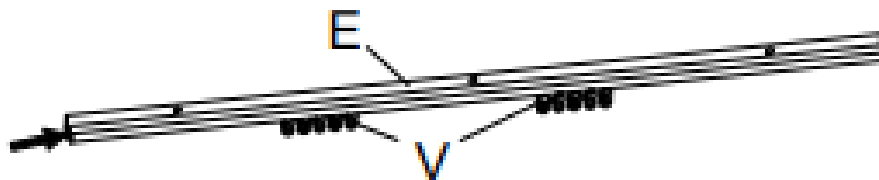
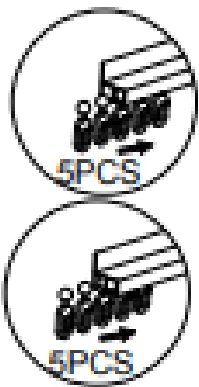

**X4**

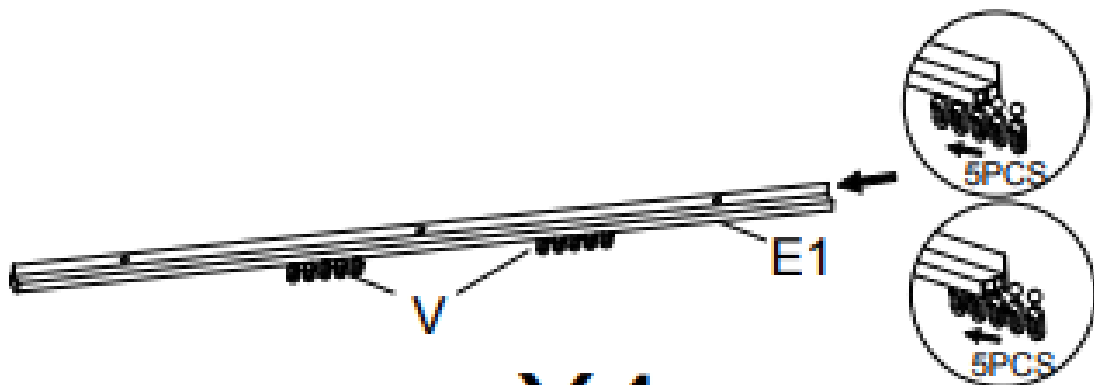

**X4**

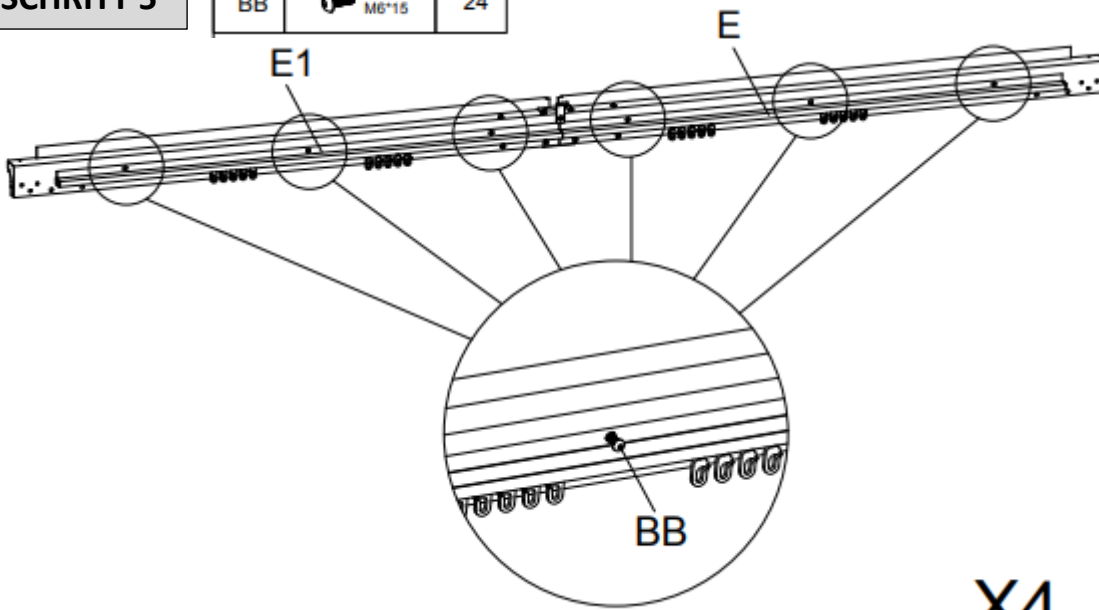

### SCHRITT 5

BB	 M6*15	24
----	---	----



X4

### SCHRITT 6

AA	 M6*20	20
L		4
J		4

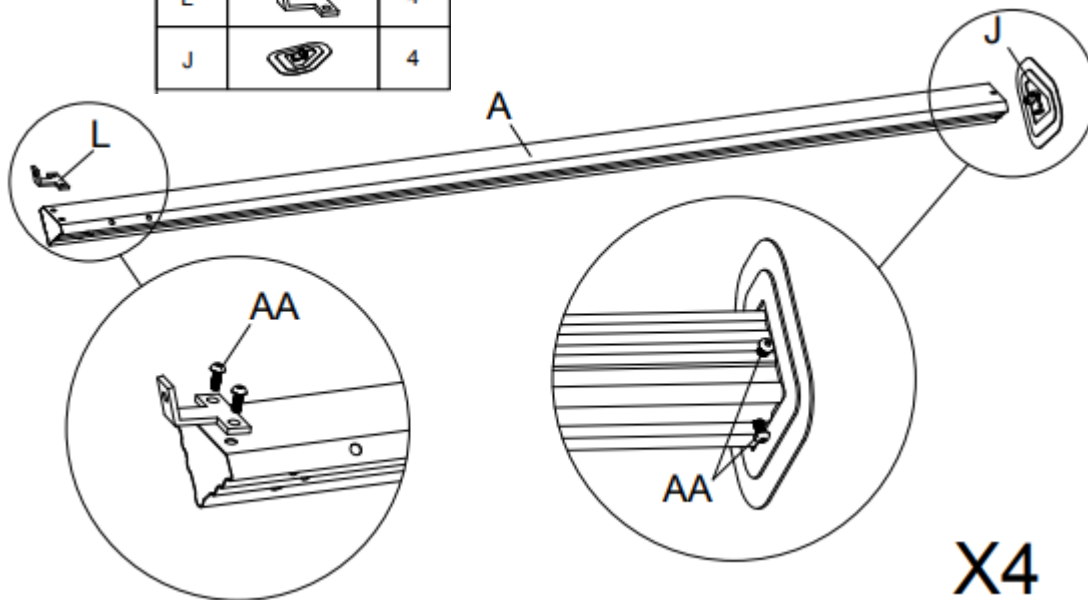

X4

SCHRITT 7

AA

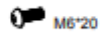

12

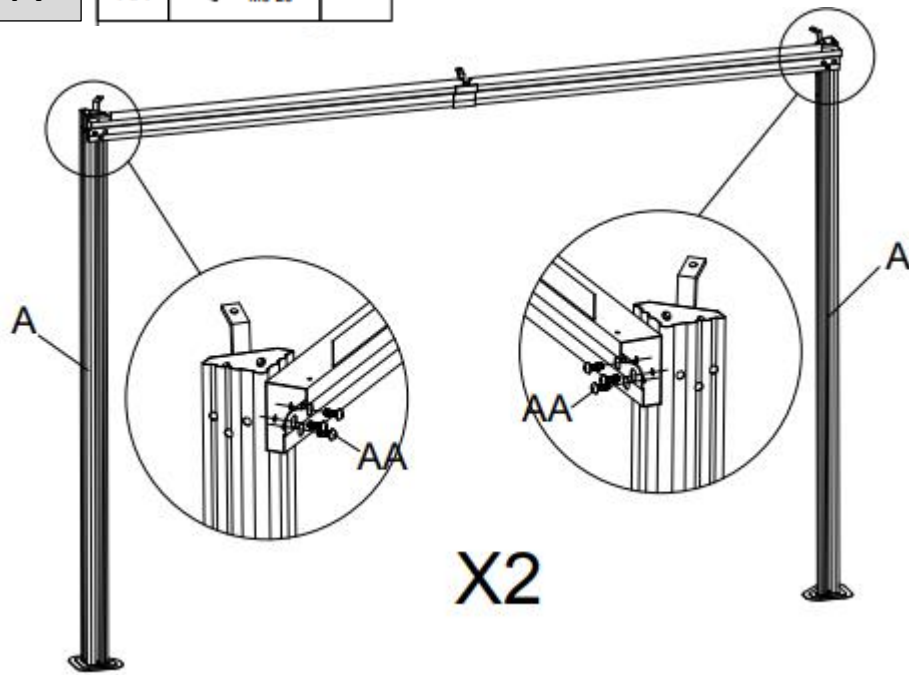

SCHRITT 8

BB



16

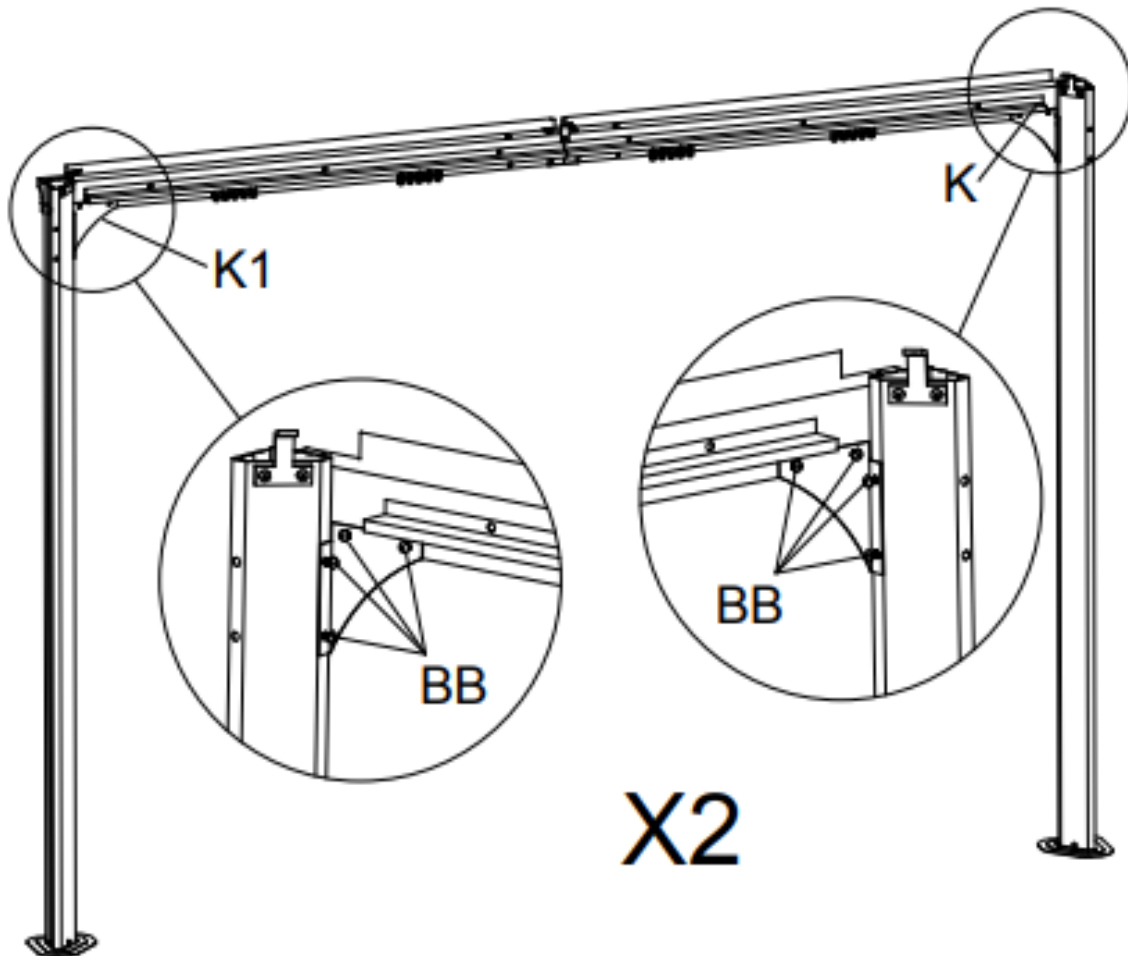



# SCHRITT 9

AA



12

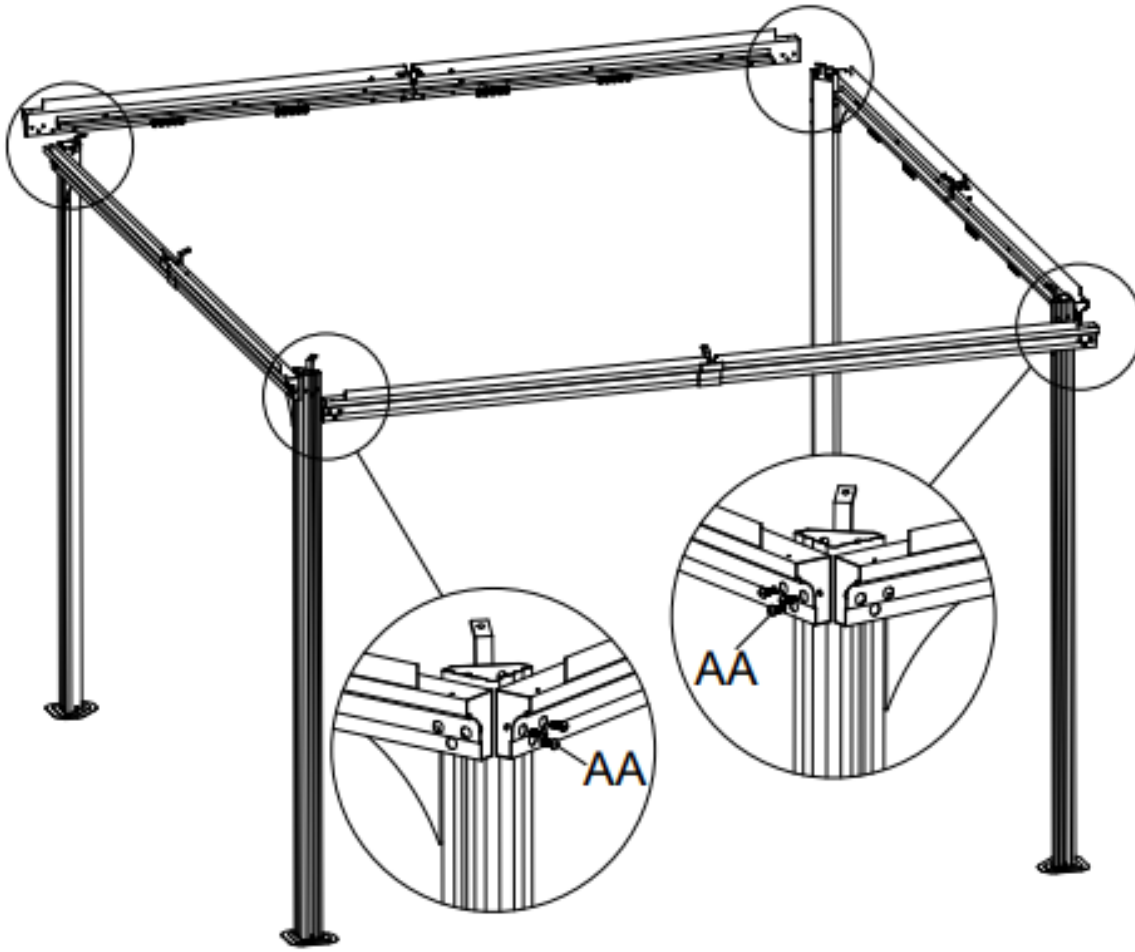

# SCHRITT 10



BB

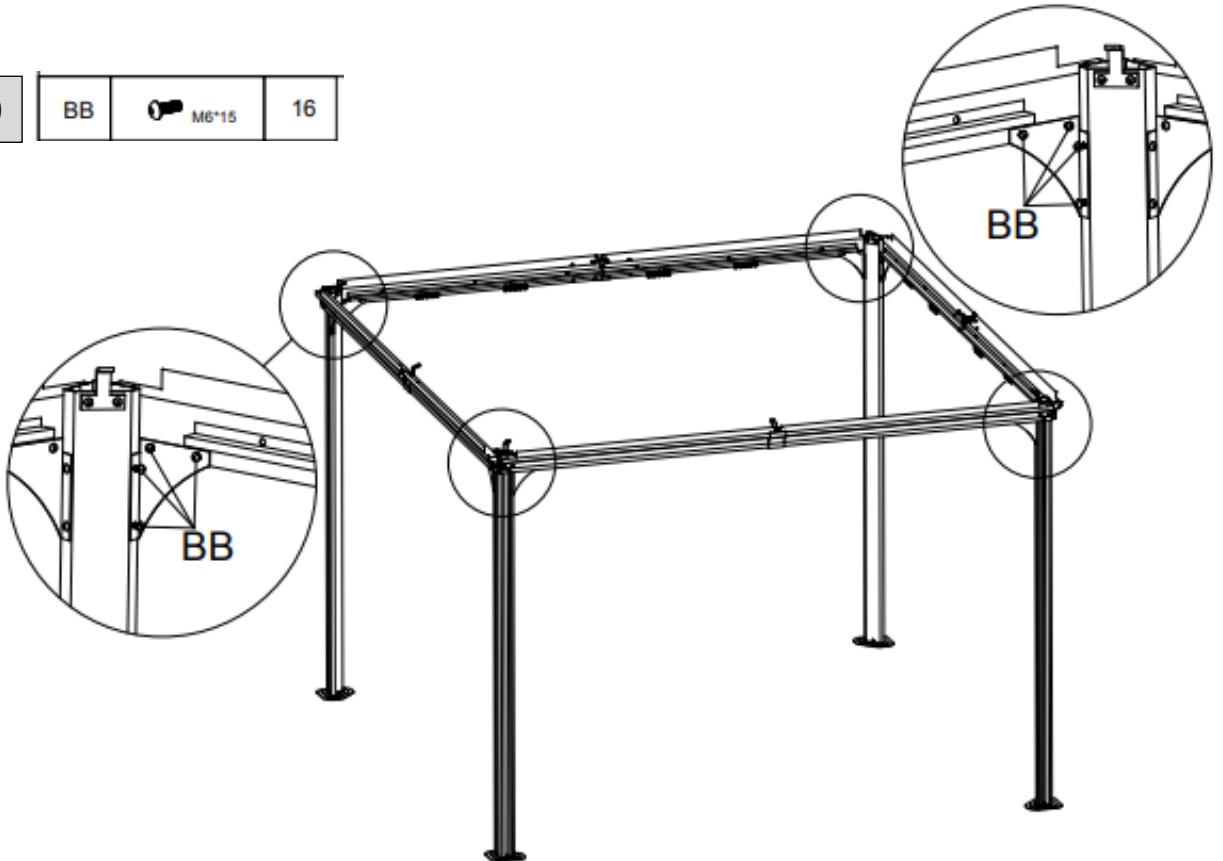

16



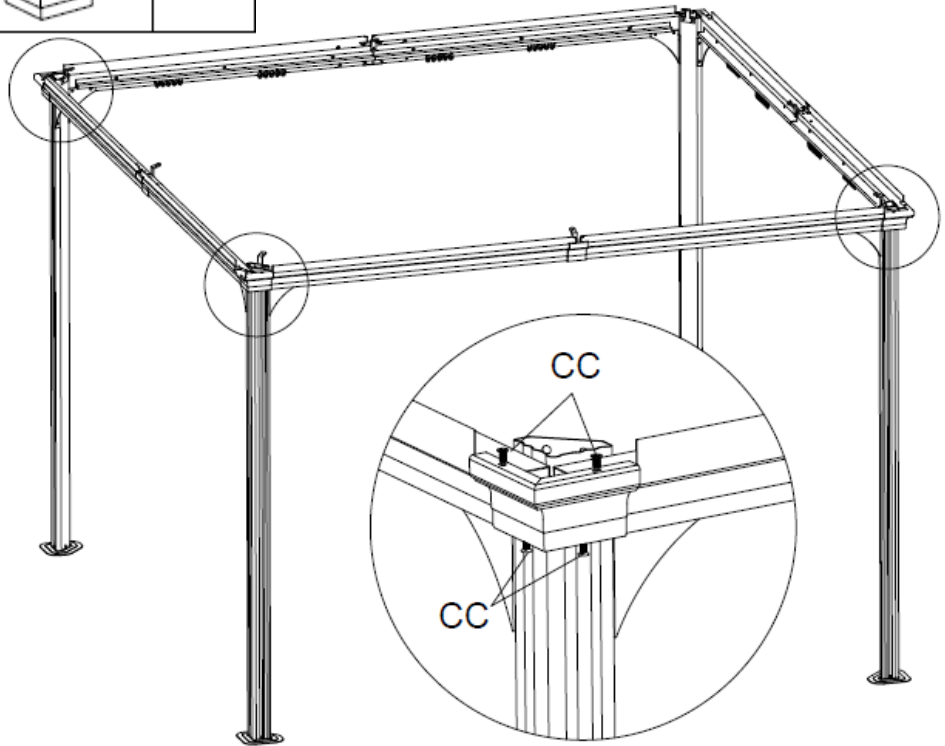

**SCHRITT 11**

CC	 M5*15	16
P		4





**SCHRITT 12**

AA	 M6*20	8
BB	 M6*15	8
H		1

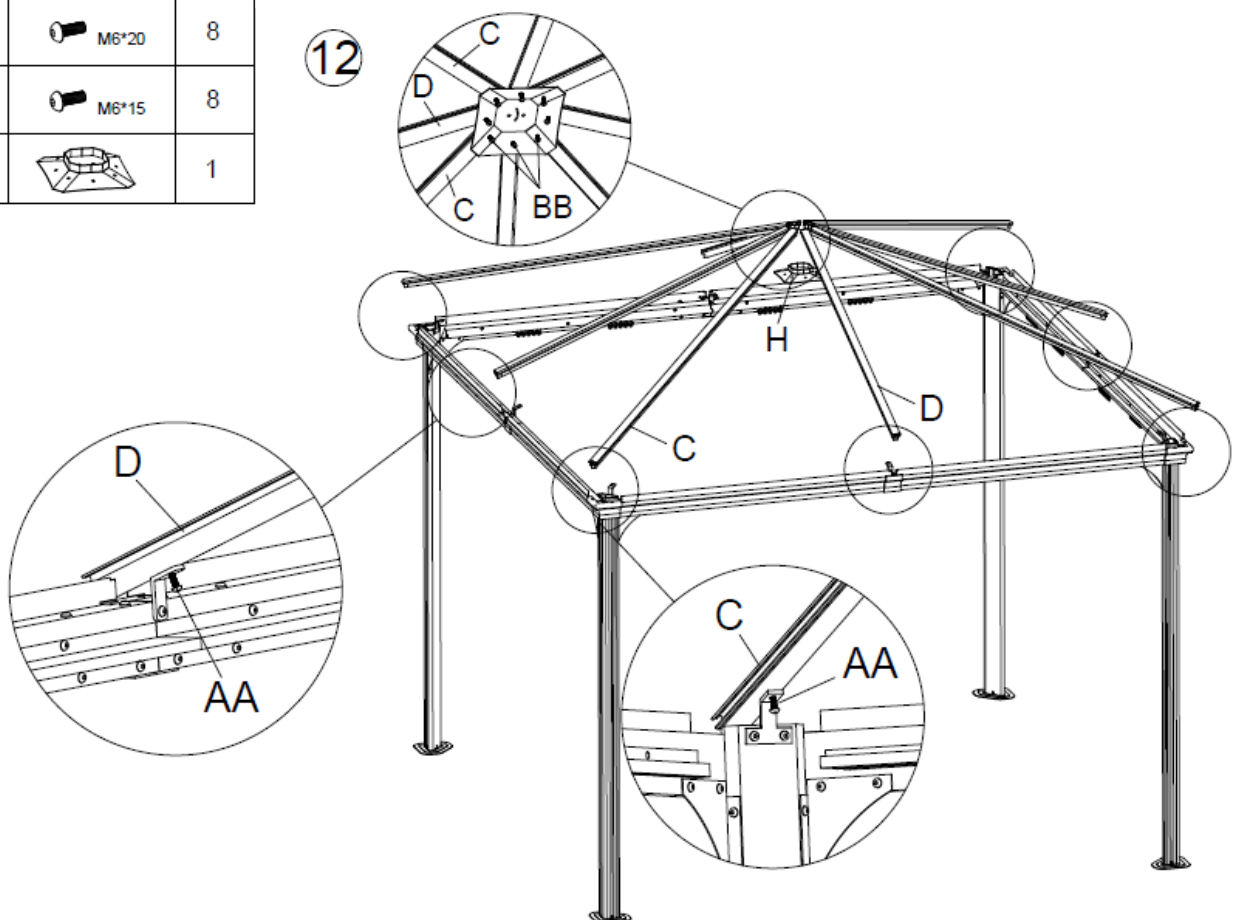
12



**SCHRITT 13**

AA	 M6*20	2
I		1

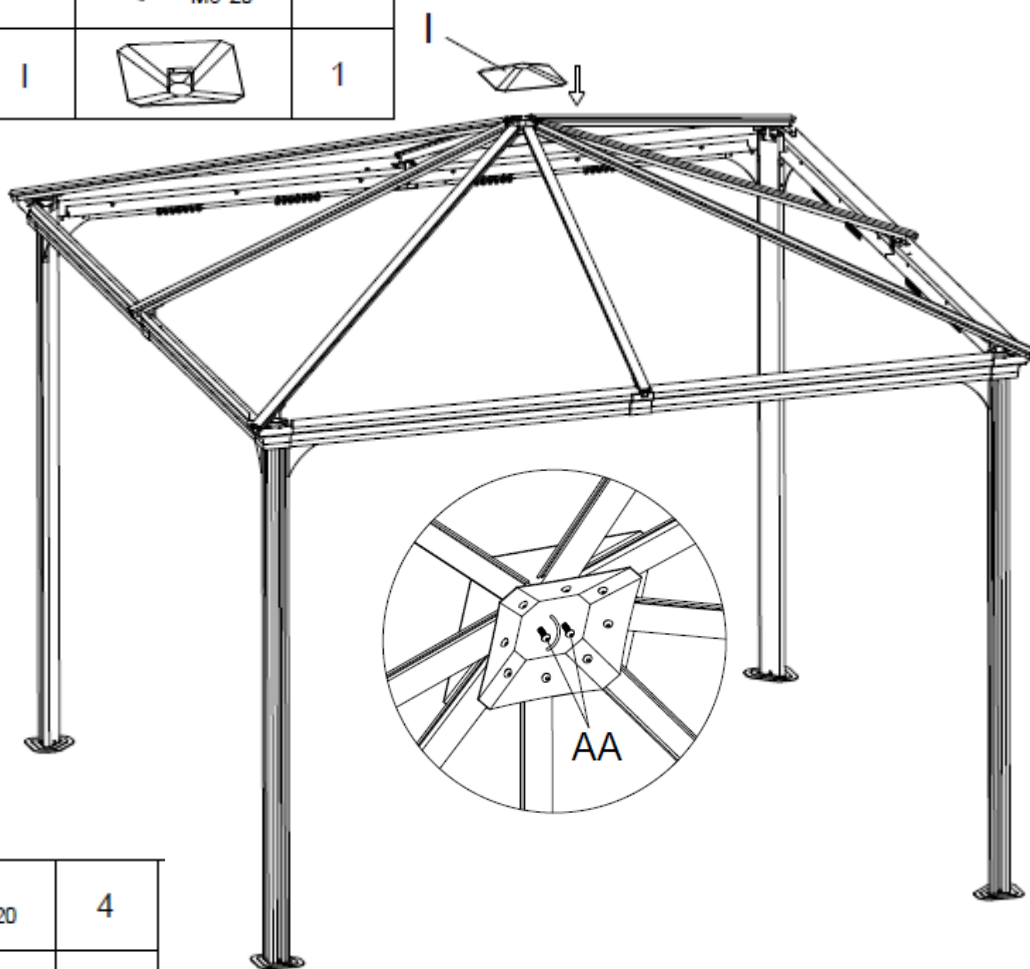

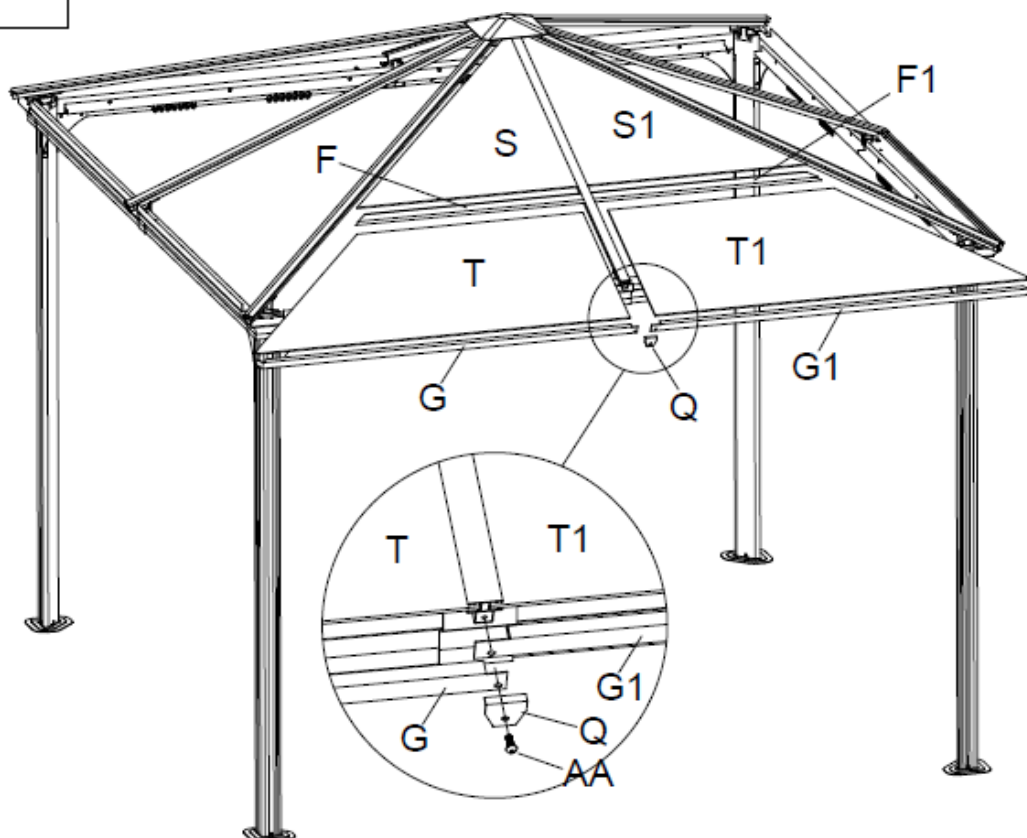
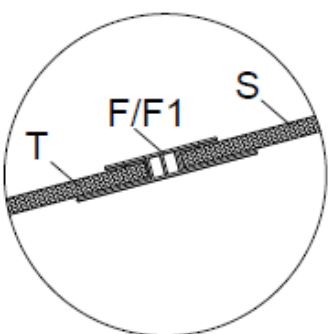
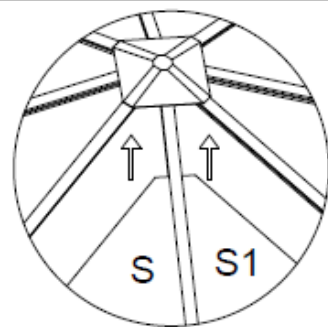

**SCHRITT 14**

AA	 M6*20	4
Q		4



### SCHRITT 15

AA	 M6*20	4
R		4

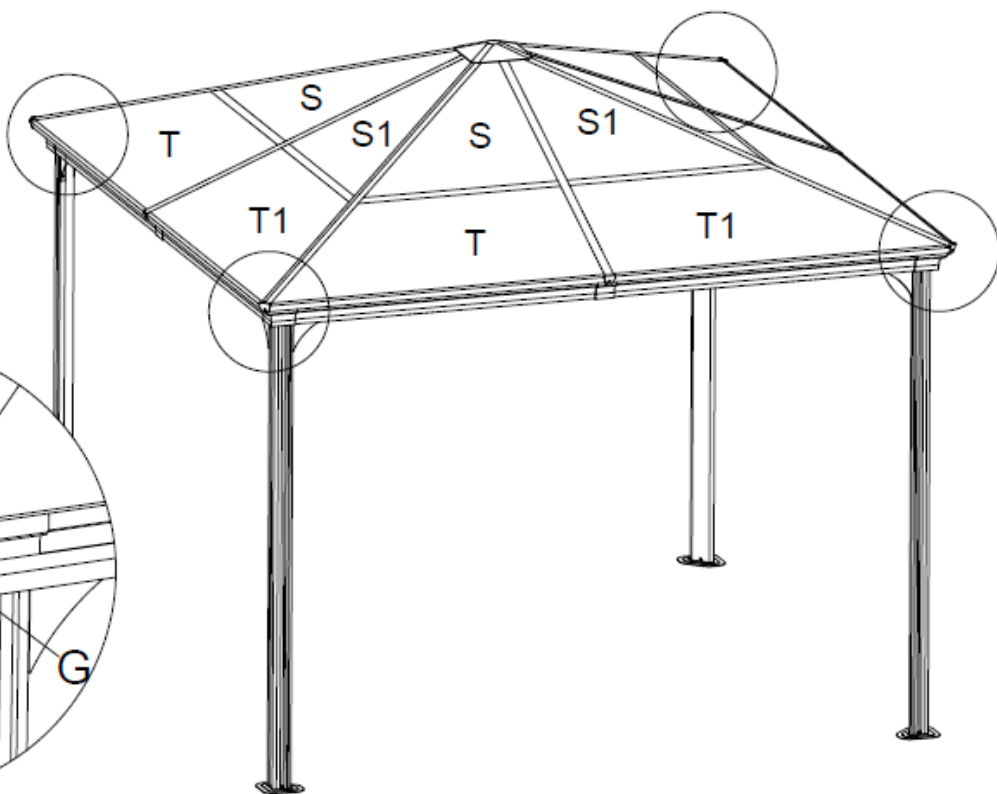
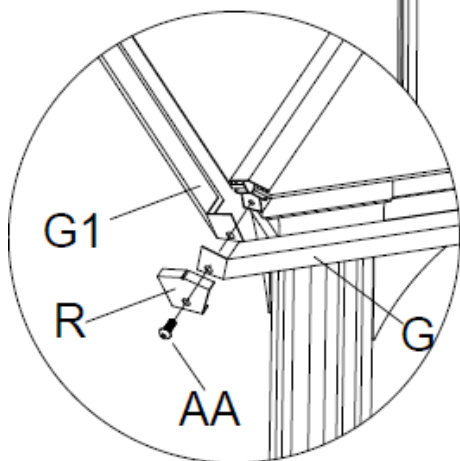

### SCHRITT 16

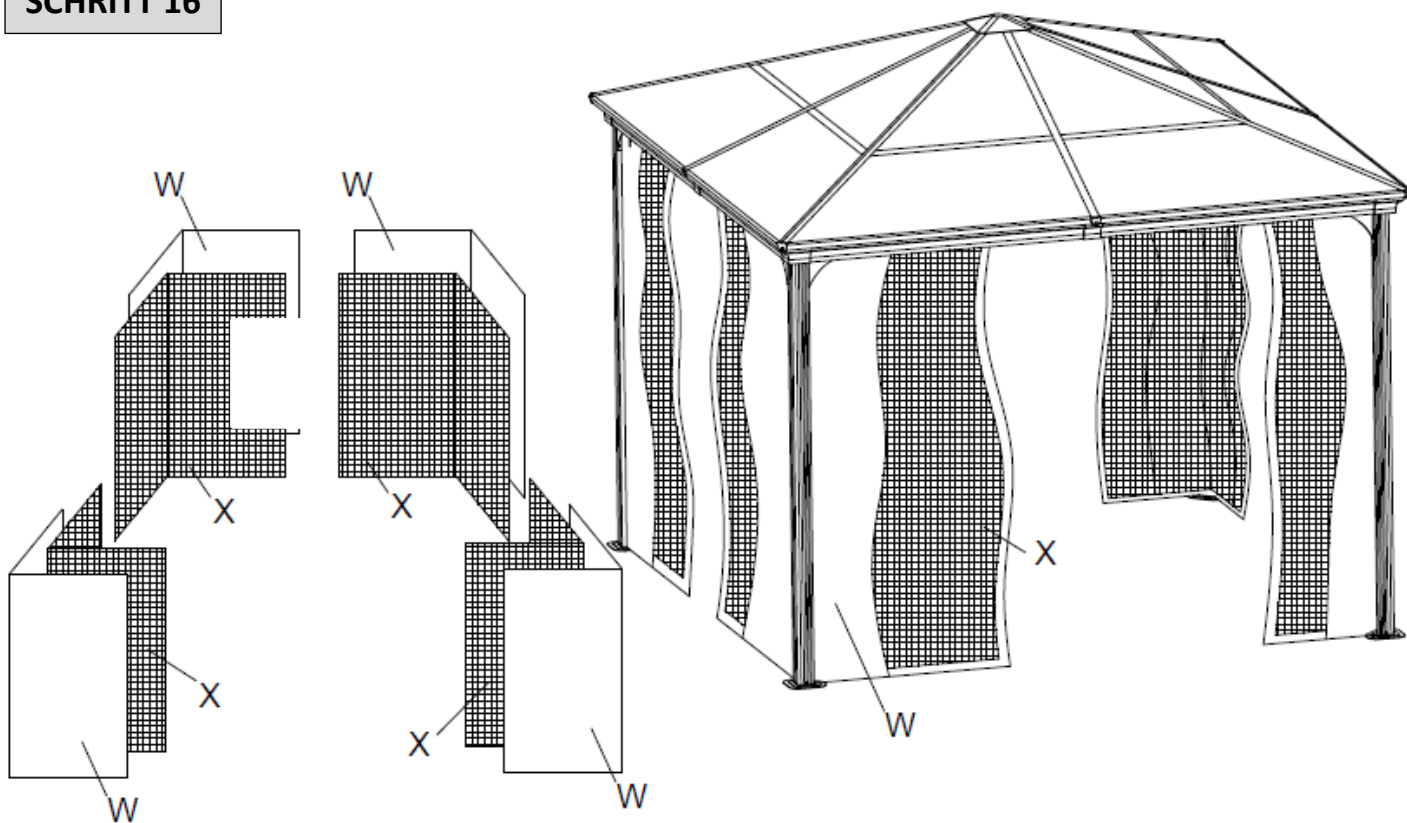



### Sicherheitshinweise:

Wir empfehlen den Pavillon am Boden zu verankern.

Hohe Schneelasten auf dem Pavillon sind zwingend zu vermeiden!  
Befreien Sie das Dach bei Schneefall unverzüglich vom Schnee.



KBW Trading GmbH  
Gewerbering 2  
88518 Herbertingen  
Deutschland  
Tel: 07586-921160  
Fax: 07586-9211616  
E-Mail: [info@jet-line.de](mailto:info@jet-line.de)  
[www.jet-line.de](http://www.jet-line.de)

