

LED Panel Light Installation

1. Note:

1. Pls put a soft mat on the floor before installing the power supply, lest scratches or damaged panel
2. The Power fixed position and direction are not limited
3. In order to ensure products shine achieve the best effect, Please carefully take and put when place the panel lamp.

2. Make the power output terminal link to the panel lamp input

1. Please note the power wiring of positive and negative when installation power wiring (positive with word)
2. Connect into the panel lamp terminals power wire needs to tighten with the screw
3. To avoid danger, pls cut off power supply before connecting wiring.
4. Lock the screw, pls not use greatly forcibly, lest crush the led panel light

3. Make the power input terminal received AC power supply

Warning:

1. Please note that power wires' negative source, when installation
2. Handle properly insulation in joint local, prevent leakage and emerge risk
3. Wiring must cut off power supply, prevent occur the danger

Embedded installation of led panel light

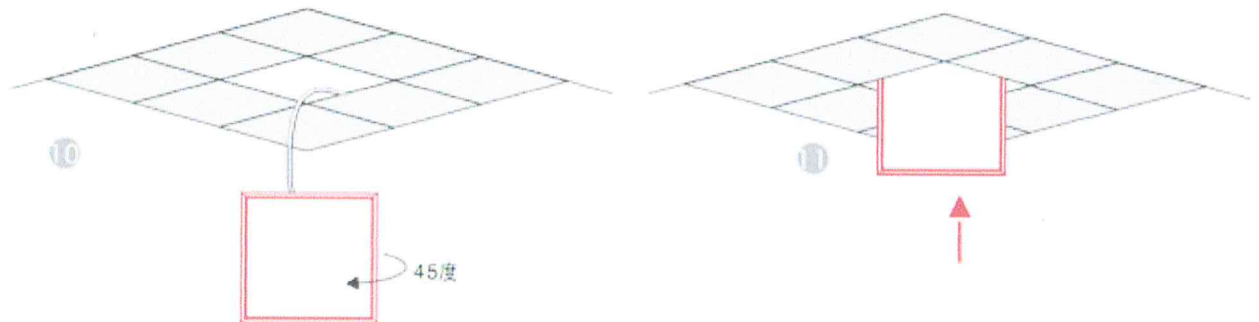

1. Make the panel light placed above the ceiling

Note:

1. Taken the ceiling and LED panel light turn 45 degrees, and put it above the ceiling, pls do not force squeezing or through the ceiling
2. please placed panel lamp handled with care, ensure the products shine with the best effect
3. Choose embedded installation LED panel lamp, first consideration that whether the panel light and the size of the ceiling corresponds

2. Make rotating face of the panel lamp down (FIG.12.13)

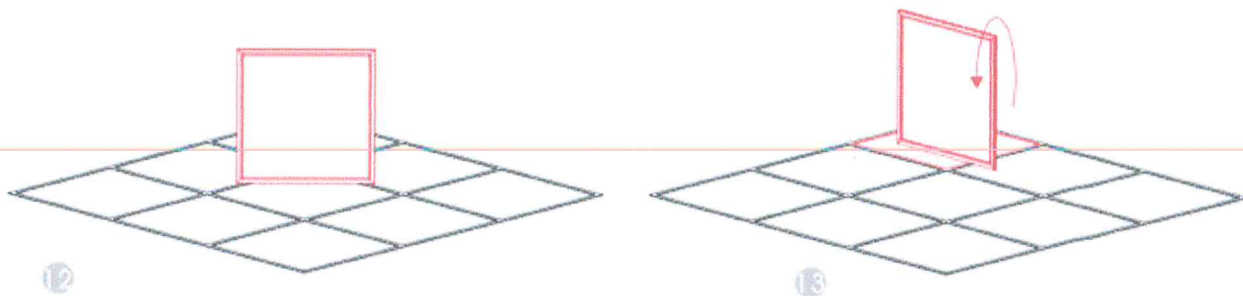

3. Make the panel light and the ceiling lanterns position adjustment aligned, that is to say, completed the installation process (FIG.14)

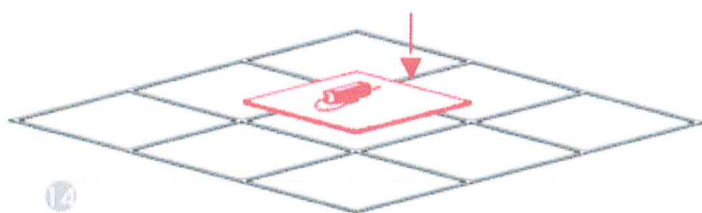

4. You can open power and lighting, when the Panel lamp completed installation (figure 15)

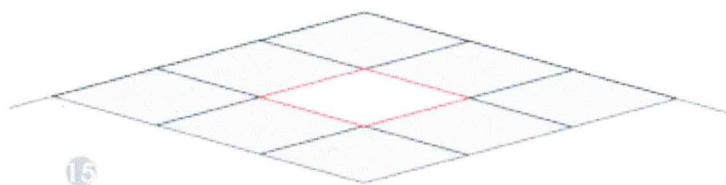

Important:

1. Pls checking and ensuring all joints is right connected after completed the installation
2. Check and ensure all positive and negative of the joints power is correct
3. Check all lock screw parts whether fixed lock

Suspension installation of led panel light

1. Make the corner fixing parts installed above panel lamp

Note:

1. Pls put a soft mat on the floor before Installing corner fixing parts , lest scratches or damaged panel
2. please placed panel lamp handled with care, ensure the products shine with the best effect
3. Lock the screw, pls not use greatly forcibly, lest crush the panel lamp

2. Make the corner fixing parts installation the ceiling top

1. The first open four $\phi 5\text{mm}$ holes on the ceiling
2. Make the glue plug put into open good holes
3. Screw through fixed cap, locked in plug hole

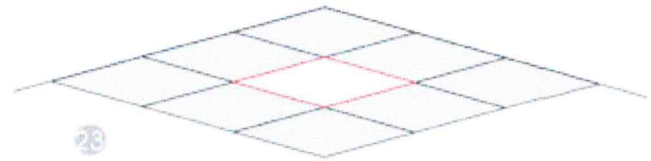
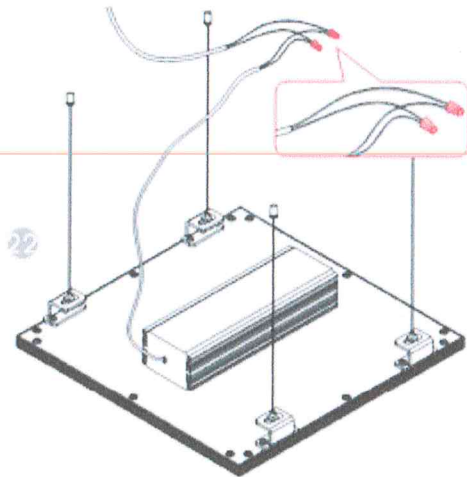

4. Power input connected with AC power supply (FIG.22)

5. LED Panel lamp installation completed effect —open power and lighting (FIG. 23)

Important:

A: Pls checking and ensuring all joints is right connected after completed the installation

B: Check and ensure all positive and negative of the joints power is correct

C: Check all lock screw parts whether fixed lock

LED panel light's average life-span over 100,000 hours (equivalent 10 years), and more 20 times than the common products, stable operation . Saving the maintenance cost of operation can completely made up for original investment. LED small fever, compare with the traditional of lamps and lanterns, the LED panel light's consumption of power only 10%-20%, which makes them more environmentally friendly, and more correspond with user's lighting budget.

Attention:

For the installation of LED lamps we recommend only by professional

KBW Trading GmH

Gewerbering 2

88518 Herbertingen

www.led-lampen-discount.com