

Massage Bathtub

Instructions of Installation and Use



MT-HX2001

Dear Customer,
Thank you for choosing our product. For your safe concern, please take a few minutes to read this manual before installation and use.

WARNING

1. For a person who has heart trouble, high blood pressure & sugar diabetes should not take a steam shower or bath when feeling sick. (The kid is suggested to be accompanied by an adult when taking a bath)
2. Don't take a bath alone after drinking wine with alcohol or excess sports.
3. The water temperature should be below 45°C during shower and the recommended temperature is 30°C-38°C.
4. Don't take a bath for a long time. Recommended time: 15-21minutes.
5. All the information in this instruction are subject to change without prior notice.
6. Settings, configurations and details of the products are subject to be changed or upgraded without prior notice.
7. For the maintenance, please contact the technicians appointed by the dealer and don't disassemble and fix by yourself, or the supplier will be free from any consequences that may occur.

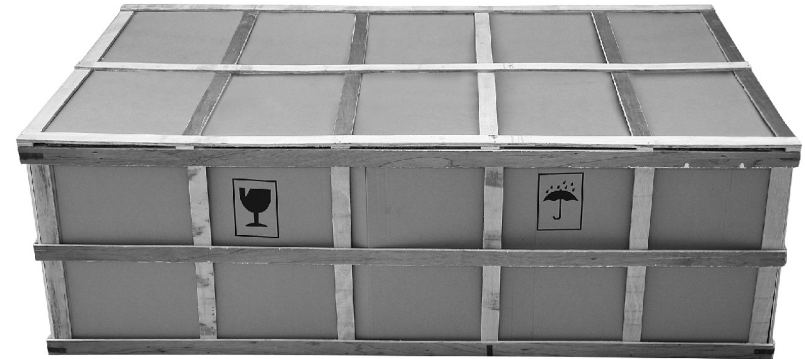

Please make sure all accessories are in the package



Drain cover 1pcs

Installation Tools:(no included)



Tape measure



Open spanner



Adjustable spanner



Thread sealing tape



Gradient

CONTENTS:

Preparations	Page2
Installation Process	Page4
Instruction of Using Our Products	Page7

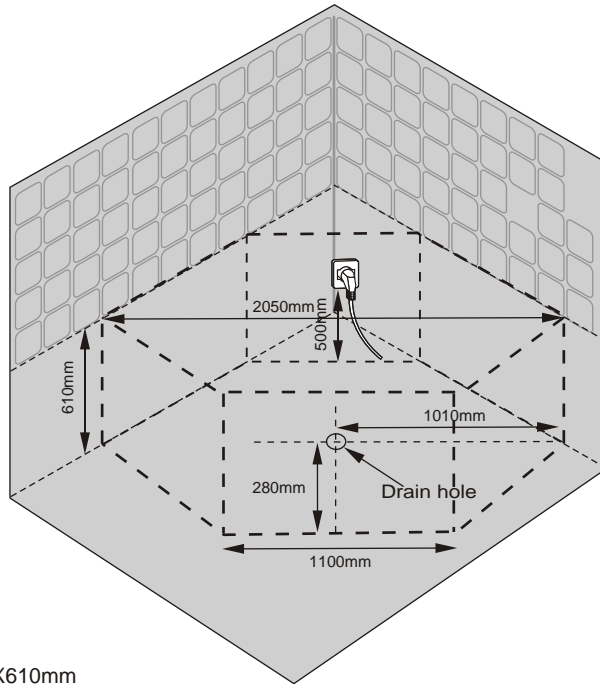

MODEL: MT-HX2001
SIZE: 2050mmX1100mmX610mm

MODEL: MT-HX2001-b
SIZE: 2050mmX1100mmX610mm



- 1 Big Water Jets
- 2 Light
- 3 Small Jets
- 4 Volume Control
- 5 Light Switch
- 6 Surfing Switch
- 7 Drainer Switch
- 8 Water Circulation
- 9 Drainer

MODEL: MT-HX2001-c
SIZE: 2050mmX1100mmX610mm

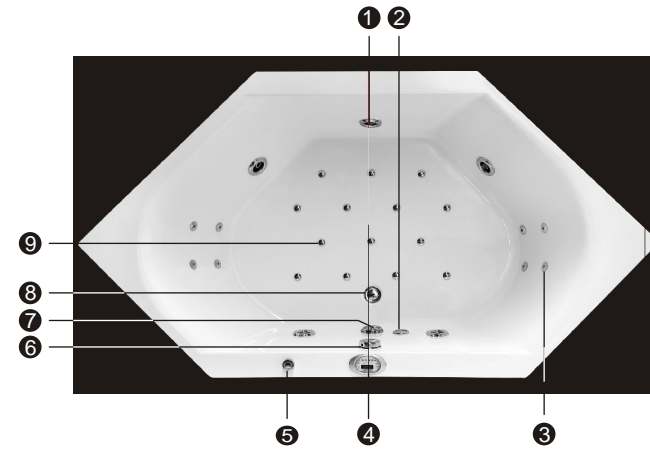

- 1 Big Water Jets
- 2 Light
- 3 Small Jets
- 4 Control Panel
- 5 Volume Control
- 6 Drainer Switch
- 7 Water Circulation
- 8 Drainer
- 9 Air Jets

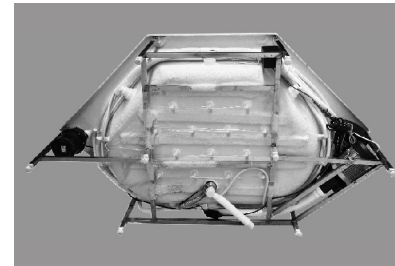

1. Side up the bathtub, then install downcomer



2. Use thread sealing tape to wrap around the drain hole



3. Make the thread sealing tape smooth



4. Fasten the drain tube

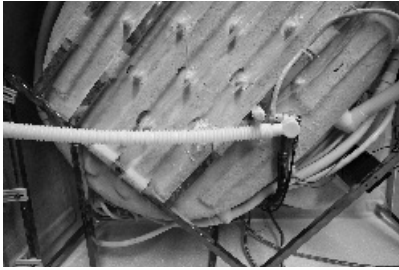

5. Put downcomer into the drain hole on the ground



6. Put plugs into the drain hole

7. Seal the barhtub edge by silicon glue as follows

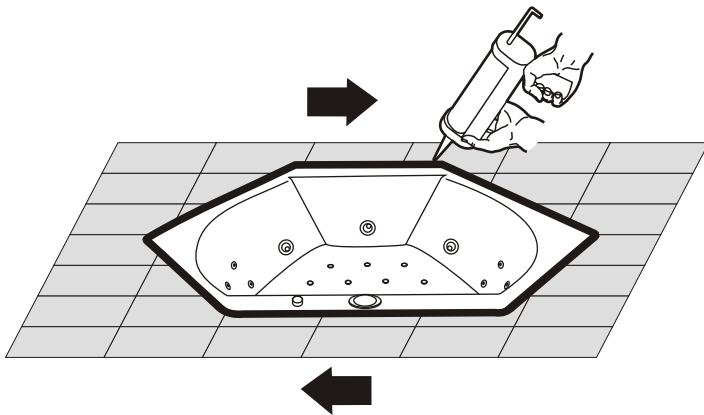
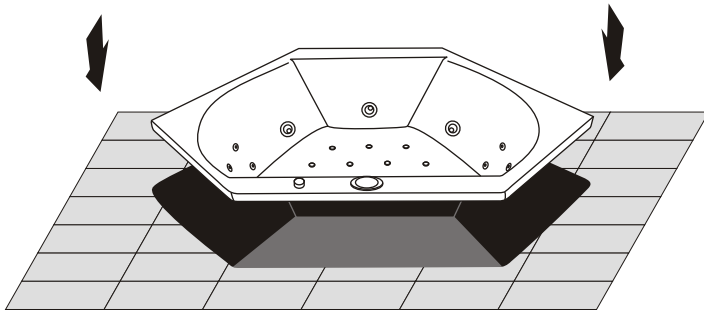

Unique Point:

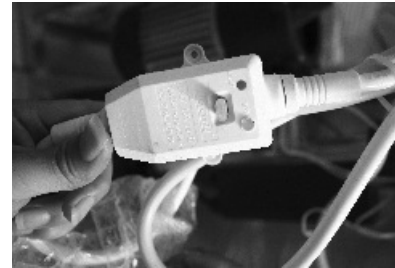

1. The creepage protector will automatically cut off the circuit if the current is too high.



2. Volume control



3. Waste water free piping system

I . SYSTEM INSTALLATION SKETCH

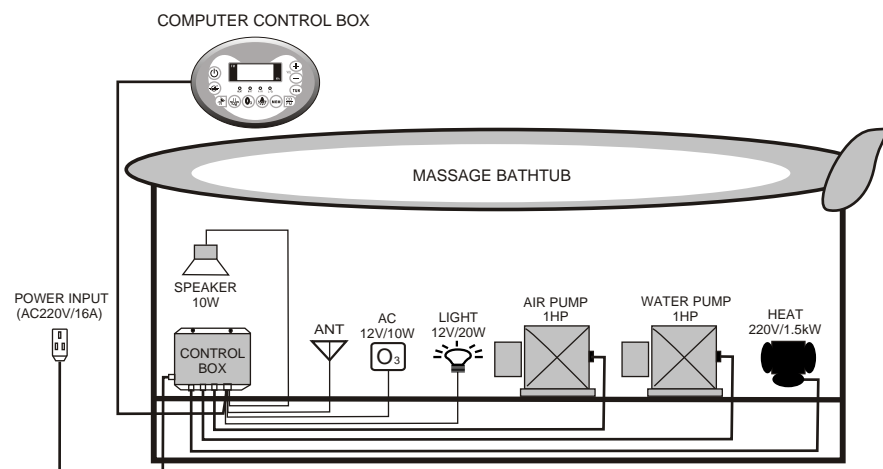

II . CONNECTION DIAGRAM

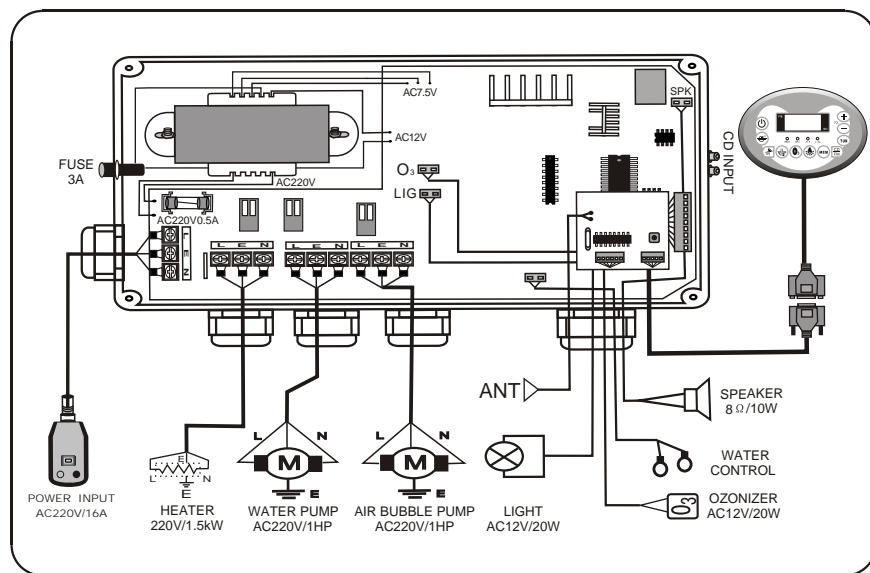

III. EXTERIOR DESCRIPTION: (CONTROL PANEL)

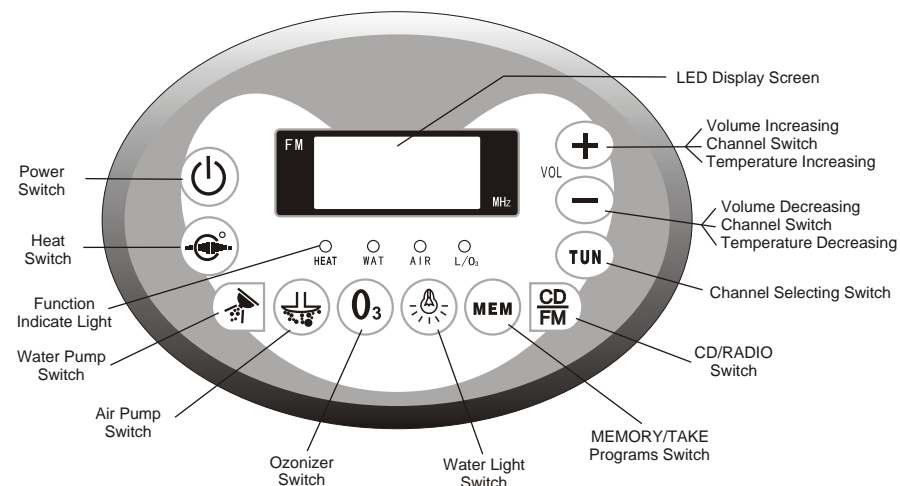

IV. DESCRIPTION OF FUNCTION INDICATE LIGHT:

1. Heater Indicator: Heater starts to work if it is on. (Remarks: during the operation, the indicator turns off automatically if there is no sufficient water; when the water level reaches the standard, the indicator is on and the heater starts to work again)
2. Water Indicator: If it is on, the massage function is effective; if it flashes, it shows that there is no sufficient water so the massage function is of no effect.
3. Bubble Bath Indicator: if it is on, the bubble bath function is effective, if it is off, this function is off.
4. O₃ Indicator: if it is on, the underwater light is on, if it flashes, the ozonation function is effective. (Remarks: when the underwater light is on and ozonation function is effective, this indicator will flash 5 times and pauses once then continue to flash!)

V. NOTES FOR DIGITAL DISPLAY:

1. LED-display screen: the display shows different when pressing (⏻)key/(⏻)key continuously. The display shows alternately (Measure Temperature/Setting Temperature/FM Radio Frequency) when heating and radio are both working.
2. When the RADIO:

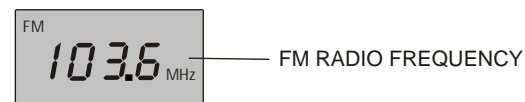

VI. TECHNICAL DATA

1. Voltage: AC220V±10%, 50Hz
AC110V±10%, 60Hz
2. Power: 3500W
3. Dielectric Strength: 1500V, 1min
4. Lighting Load: AC12V, 20W
5. Music Power: ≤15W
6. Frequency Range: FM88-108MHz
7. S/N Radio: ≥45dB
8. AIR PUMP: AC220V50Hz≤1kW
9. HEAT POWER: AC220V50Hz≤1.5kW
10. Ozone: AC12V≤20W
11. WATER PUMP: POWER≤1kW

VII. OPERATION MANUAL

Power on/off
Please Press (⏻)Key

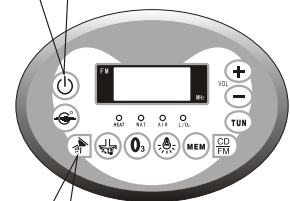

(1). Water Pump
Please Press (🚰)Key

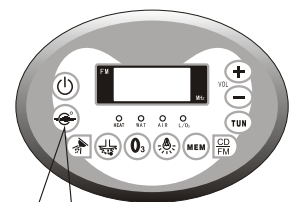

(2). Heater
Please Press (🔥)Key

1. Power:

Surfing Operation: Connect the creepage protector, press (⏻), the system starts to work, LCD screen shows the actual temperature. At this moment, you can select the functions desired; Press (⏻) to turn off the system.

(1). Water Pump:

Press (🚰), the pump is turned on, and the LED indicator is on correspondingly; press again (🚰) to turn off the pump; (Notice: When there is not sufficient water in the tub, the system will shut off the pump and the indicator will flash until the water level reaches the standard)



(2). Heater:

The water pump has to be activated before using the heater. The computer establishes(45℃). Press again (🔥)key, heat function to OFF.

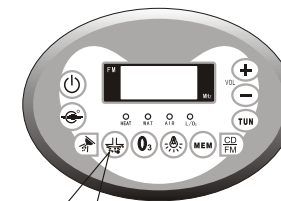
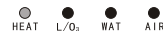

(3). Bubble Bath
Please Press (🛁)Key

(3). Bubble Bath:

Press this button (🛁) on the panel to switch on/off bubble bath function and the indicator related will be on/off accordingly.



(4). Ozonation
Please Press (O3)Key

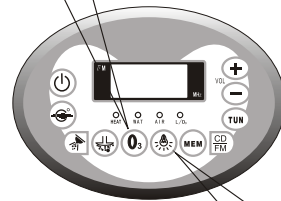

(4). Ozonation:

Press (O3) to turn on/off this function and the indicator related will be on/off accordingly. (Remarks: each time the ozonator works for 10 minutes, after10 minutes,the system shut it off automatically.)



(5). Underwater Light
Please Press (💡)Key

(5). Underwater Light:

Press (💡) to turn on/off the light and the indicator will be on/off accordingly.



(6). Temperature Setting
Please Press The (VOL) Key

(6).Temperature Setting:

Press the (VOL) button to set the water temperature in the tub, the setting ranges: (20℃-50℃). Press (VOL+) to increase the preset temperature, press (VOL-) to decrease the temperature and the screen shows accordingly. (Remarks: For this function, FM & DC should be turned off first, otherwise, it is for volume adjustment) Preset Temperature by factory: 45℃

2. FM Function:

- (1). Pull out the antenna and set it as Y type, press (CD/FM), the screen shows FM frequency, the volume indicating as DB increases to “00dB ” from “ 08dB ” .
- (2). Press(TUN)key to upward tuning, interval press is for manual selecting. If the key is held for over 2 seconds, the frequency will stop at the channel the digital founds.(Notice: You can press(+)key for upward and press(-)key for downward. In the case of the weak signal, manual selecting is suggested.) Press(MEM)key when a channel is selected, the screen will show “P----*” , and the channel will be memorized.(Notice: The “*” of the “P----*” is positioned memory number, the capacity of memory is 10.) If the received signal is weak, unfold the antenna and readjust. Press(MEM)key to select the channel you like after setting.
- (3). Volume Control: Press the volume(+)or(-)to adjust the volume, the correspondent DB will be indicated in the screen.

3. External CD:

Connect the CD audio wire with the external socket of the main control box, press CD/RADIO for CD function, then choose the desired volume by pressing (VOL+) or (VOL-).

4. Key Description:

- (1). It is the store function after pressing (TUN) or after station selection; and direct pressing of the(MEM)key is selecting the channels that have been memorized.
- (2). (VOL+) and (VOL-) Function: it is for temperature adjustment when the radio and CD functions are ineffective, while the radio or CD functions is effective, it is for volume adjustment; when the radio function is effective, press(TUN), it is for station selection.
- (3).It is for tuning upward function, and also the station searching function by pressing (VOL+) or (VOL-).

VIII.PRECAUTIONS:

1. The installation should be carried out by a qualified technician and creepage protector should be installed in the place easily to be controlled.
2. The electronic parts should be well grounded, otherwise, the manufacturer will not be liable for any loss or consequences occurred.
3. The load capability of the power supply should be considered during installation, or it affects the normal operation of the product or may lead to accident!
4. For any functions can not be activated through the ways mentioned above, please contact a certified technicians or local dealer.
5. If you don't use the product for a long time, please disconnect the main power supply.

Cleaning&Maintenance

1. During the transportation or installation, do not pull the pipe or hold accessories to avoid the water leakage.
2. After long time use, if there are some dirt on product's surface, wipe it off gently by a soft towel stained with mild detergent; for the metal parts, polish it with some car wax by a towel, which brings out a refreshing appearance.
3. Scale deposit can be wiped off with warm citric acid or vinegar by a soft cloth.
4. Don't clean the tub and accessories with hard or coarse material to avoid any scratches.
5. Don't clean the tub and accessories with gasoline to avoid any damages.
6. It is not recommended to leave water in the tub for a long time or use this tub for washing purpose. Pls drain off the water after the bath and disconnect the power supply.
7. There should be sufficient power supply and wires should be safely grounded.
8. For your safty, a professional technician is necessary to ensure earthing wire be well grounded and a RCCB fitted during installation.